

# PACKAGING

## CHEAT SHEET

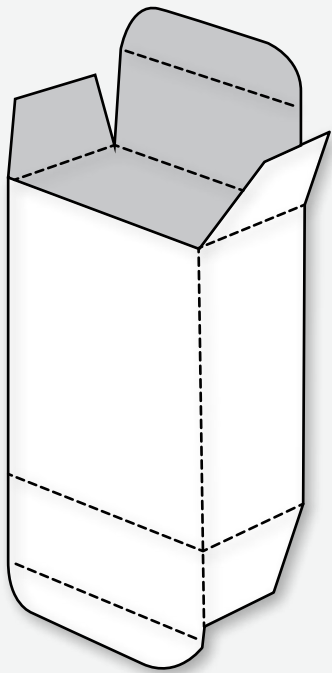

### TUCK ENDS

Tuck-end cartons are one of the most basic boxes, and one of the most widely used. There are two variations: straight and reverse. Reverse tuck ends – where one tuck flap is joined to the front panel and the other attached to the back panel – tend to be less expensive than the straight tuck ends where the tuck flaps are both attached to the front panel. This slight variation allows for nesting, or ganging, on the press sheet to be maximized.

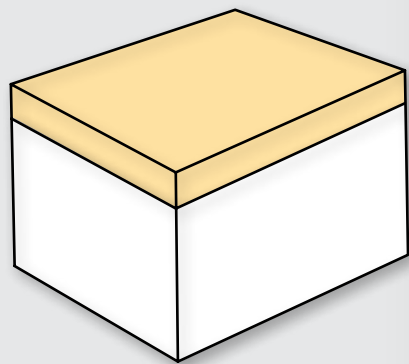

### SHOEBOX LIDS

Shoebbox lids offer easy opening, making them ideal for packages that are opened and closed frequently. Shoebbox style lids are always 1" deep, regardless of the box's base size.

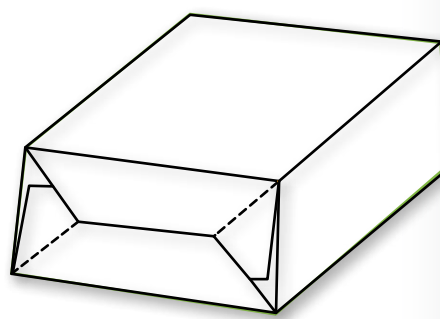

### AUTO BOTTOMS

Auto-bottom boxes can do wonders to increase efficiencies and save money in reduced labor costs. Pre-glued flaps are positioned in such a way that a solid bottom panel forms when the carton is erected.

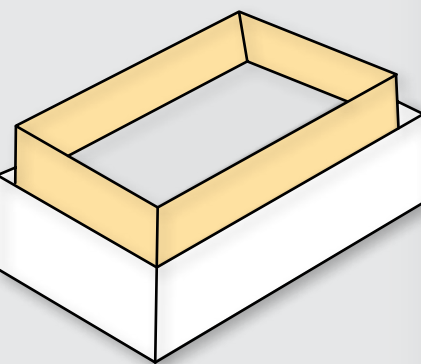
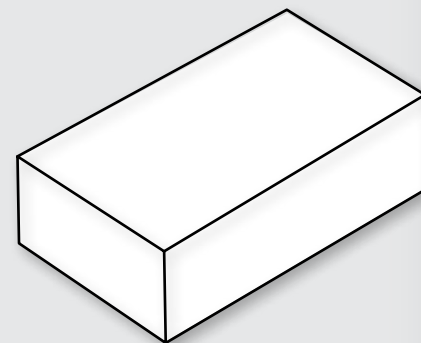

### SHOULDER/NECK

Shoulder/neck boxes incorporate a raised neck that enables the lid to fall flush with the base of the carton. They are often used in high-end beauty and spirit packaging.

**Design Tip:** There are many directional changes with neck boxes. For maximum impact, carefully consider the placement of design elements on the inside & outside of the neck.

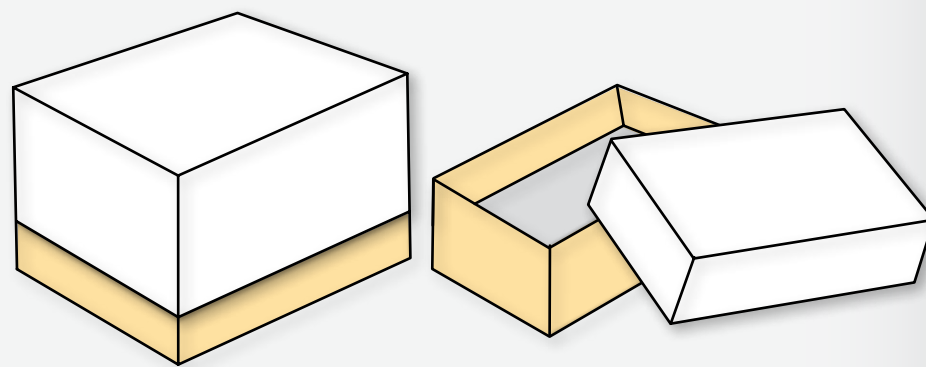

### TELESCOPING LIDS

Telescoping lids refer to those boxes whose lid covers the entire depth of the base it's covering, similar to those used in chocolate stores. They provide a little more protection when you know the carton won't be opened and closed too frequently. If you prefer the look of the telescoping lid but know the package will be opened repeatedly, you may want to incorporate thumb notches to help the boxes open more easily. (Partial telescoping lids are available when you need a lid deeper than 1", but don't want it to completely cover the base. Jewelry and gift boxes are well known for this as they offer practicality and charm in an easy to open carton.)

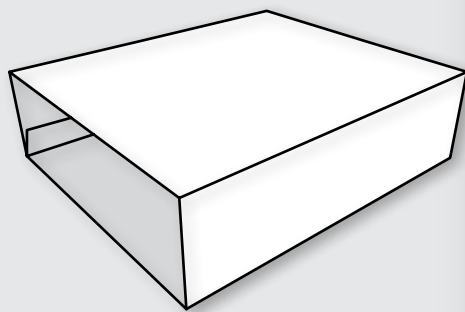

### SLEEVES

Sleeves are commonly used as slip covers for trays, or even directly over products. They are glued along the depth of the carton in manufacturing, and often feature a cover similar to those you'd find on custom software boxes.

**Design Tip:** Knockout is required for proper adhesion along glue flaps. Consult with your service provider to ensure adequate space is accounted for.

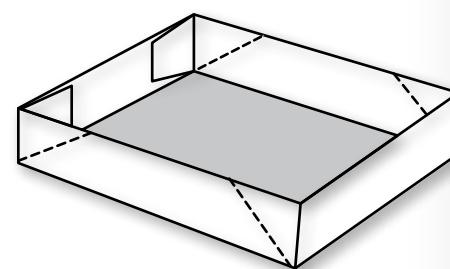

### TRAYS

Tray folding cartons come in a wide array of formats, including both glued and non-glued corners. Tray cartons are typically used as custom food boxes, medical boxes and pharmaceutical packaging.

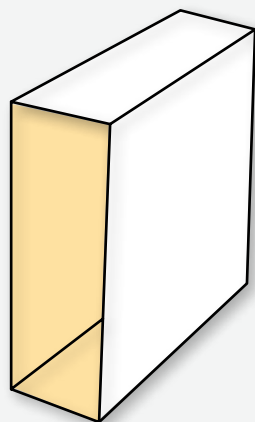

### SLIPCASES

Slipcases are typically paired with an inner tray. Slipcases are protective boxes that feature one or more open ends and are often used to protect DVDs and books.

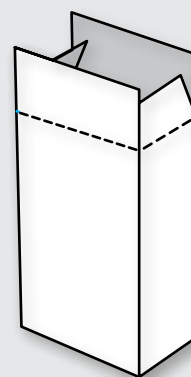

### SEAL END

Seal-end cartons are ideal for automated lines. Prior to product fulfillment, the cartons are glued along the depth of the box. Once the carton is filled with product, the ends are then sealed with glue making them tamper evident on the shelf.

### GET FURTHER INSIGHTS

into the packaging world – including behind the scenes glimpses into world-class packaging designs, substrate showcases, and more.

[bit.ly/PSpackaging](http://bit.ly/PSpackaging)



Cool solutions for business.